

# CertaUPS

C450R USER MANUAL  
A COMPLETE INSTALLATION  
AND USER GUIDE

## THE C450R SERIES

A rackmountable uninterruptible power supply (UPS) incorporating online double conversion technology, which eliminates all mains power disturbances.

[www.certaups.com](http://www.certaups.com)

For assistance please contact your local CertaUPS partner.

Scan to download the APP



## Contents

SAFETY INSTRUCTIONS .....	6
CERTIFICATION STANDARDS:.....	6
SPECIAL SYMBOLS .....	6
SAFETY OF PERSONS.....	7
PRODUCT SAFETY .....	8
SPECIAL PRECAUTIONS.....	8
INTRODUCTION .....	9
ELECTRONIC EQUIPMENT PROTECTION .....	9
ENVIRONMENTAL PROTECTION .....	9
PRODUCT OVERVIEW .....	10
WEIGHT AND DIMENSIONS .....	10
REAR PANELS .....	11
C450R-010-B/C .....	11
C450R-020-B/C .....	11
C450R-030-B/C .....	11
C450R-BB1 .....	11
C450R-BB2.....	11
INSTALLATION.....	12
INSPECTING THE EQUIPMENT.....	12
CHECKING THE ACCESSORY KIT .....	12
INSTALLING THE UNIT.....	13
RACK INSTALLATION .....	13
TOWER INSTALLATION .....	14
CONNECTING THE EBM(S).....	14
OPERATION .....	15
LCD PANEL.....	15
LCD DESCRIPTION .....	16
OPERATING PRINCIPLE .....	16
DISPLAY FUNCTIONS .....	17
USER SETTINGS .....	17
STARTING THE UPS WITH UTILITY .....	19
STARTING THE UPS WITH BATTERY .....	19
UPS SHUTDOWN.....	19
COMMUNICATION .....	20
RS232 and USB.....	20
UPS REMOTE CONTROL FUNCTIONS.....	20
IoT (INTERNET OF THINGS) .....	21
IoT Connection .....	21
MODULAR TCP .....	22
INTELLIGENT CARD (OPTIONAL).....	22

UPS MANAGEMENT SOFTWARE.....	22
INSTALLATION PROCEDURE:.....	23
WINPOWER VIEW APP .....	23
UPS MAINTENANCE .....	24
EQUIPMENT CARE .....	24
TRANSPORTING THE UPS .....	24
STORING THE EQUIPMENT .....	24
REPLACING BATTERIES .....	24
RECYCLING .....	26
TROUBLESHOOTING .....	27
SPECIFICATIONS.....	29
UPS BLOCK DIAGRAM .....	29
UPS SPECIFICATION.....	29

## SAFETY INSTRUCTIONS

### KEEP THESE INSTRUCTIONS IN A SAFE PLACE

This manual contains important instructions that should be followed during the installation and maintenance of the UPS and batteries.

All UPS models are considered operating at an optimal temperature of 20 – 25°C

### CERTIFICATION STANDARDS:

- Safety: IEC/EN 62040-1
- EMC: IEC/EN 62040-2
- Performance: IEC/EN 62040-3.
- ISO 9001:2015.
- ISO 14001:2015.

### SPECIAL SYMBOLS



**RISK OF ELECTRIC SHOCK** - Observe the warning associated with the risk of electric shock symbol.



Important instructions that must always be followed.



EU separate collection and lead content mark for lead-acid batteries. This indicates that the battery must not be disposed of to the 'normal' household waste but be separately collected and recycled.

**Pb**



EU separate collection mark for waste electrical and electronic equipment (WEEE). This indicates that the item must not be disposed of to the 'normal' household waste but be separately collected and recycled.



Information, advice, help.



Refer to the user manual.

## SAFETY OF PERSONS

- Dangerous voltage levels are present within the system. It should only be opened by qualified service personnel.
- The system must be properly grounded.
- The battery supplied with the system contains small amounts of toxic materials. To avoid accidents, the instructions listed below must be observed:
  - Servicing of batteries should be performed by personnel knowledgeable about batteries and the required precautions.
  - When replacing batteries, replace with the same type and number of batteries or battery packs. Risk of explosion if the battery is replaced by an incorrect type. Instructions shall carry sufficient information to enable the replacement of the battery with a suitable recommended type.
  - **CAUTION:** Do not dispose of batteries in a fire. The batteries may explode. Dispose of used batteries according to the instructions.
  - Do not open or damage batteries. Released electrolyte is harmful to the skin/eyes and may be toxic.
  - **CAUTION** – A battery can present a risk of electrical shock and high short circuit current. The following precautions should be observed when working on batteries:
    - Remove watches, rings, or other metal objects.
    - Use tools with insulated handles.
    - Wear rubber gloves and boots.
    - Do not lay tools or metal parts on top of batteries.
    - Disconnect the charging source before connecting or disconnecting battery terminals.
    - Determine if the battery is inadvertently grounded. If inadvertently grounded, remove the source from the ground. Contact with any part of a grounded battery can result in electrical shock. The likelihood of such shock can be reduced if such grounds are removed during installation and maintenance.
    - Failed batteries can reach temperatures that exceed the burn thresholds for touchable surfaces.

## PRODUCT SAFETY

- The UPS connection instructions and operation described in the manual must be followed in the indicated order.
- UPS enclosure IP rating IP20.
- CAUTION - To reduce the risk of fire, the unit connects only to a circuit provided with branch circuit overcurrent protection for:  
20A rating, for Tower 030-C models, trip curve C.

The upstream circuit breaker for Normal AC/Bypass AC must be easily accessible.

- For PERMANENTLY CONNECTED EQUIPMENT, a readily accessible disconnect device shall be incorporated external to the equipment.
- For PLUGGABLE EQUIPMENT, the socket-outlet shall be installed near the equipment and shall be easily accessible.
- Check that the indications on the rating plate correspond to your AC powered system and to the actual electrical consumption of all the equipment to be connected to the system.
- Never install the system near liquids or in an excessively damp environment.
- Never let a foreign body penetrate inside the system.
- Never block the ventilation grates of the system.
- Never expose the system to direct sunlight or source of heat.
- If the system must be stored before installation, storage must be in a dry place.
- The admissible storage temperature range is -25°C to +55°C without batteries, 0°C to +40°C with batteries, suggest storing the battery below 25°C.
- This UPS can be used in TN/IT/TT power systems.

## SPECIAL PRECAUTIONS

- The unit is heavy: wear safety shoes and suitable lifting equipment.
- All handling operations will require at least two people (unpacking, lifting, installation in rack system).
- Before and after the installation, if the UPS remains de-energised for a long period, the UPS must be energised for a period of 24 hours, at least once every 6 months (for a normal storage temperature of less than 25°C). This charges the battery, thus avoiding possible irreversible damage.
- During the replacement of the Battery Module, it is imperative to use the same type and number of elements as the original Battery Module provided with the UPS to maintain an identical level of performance and safety.

 This is a category C2 UPS product. In a residential environment, this product may cause radio interference, in which case the user may be required to take additional measures.

## INTRODUCTION

Thank you for selecting CertaUPS to protect your electrical equipment.

We recommend that you take the time to read this manual to take full advantage of the many features of the UPS (Uninterruptible Power System).

Before installing the UPS, please read the safety instructions. Then follow the indications in this manual.

## ELECTRONIC EQUIPMENT PROTECTION

The UPS protects your sensitive electronic equipment from the most common power problems, including power failures, power sags, power surges, brownouts, line noise, high voltage spikes, frequency variations, switching transients, and harmonic distortion.

### Special characteristic:

- Double converter with pure sine waveform output
- Full digital control
- Higher power density, and output PF = 1
- Wider input voltage range: 110Vac~300Vac
- Higher efficiency: 93% for 2K/3k, 89% for 1k
- Input THDI<5%
- Higher charger current for long backup mode:8A, adjustable from 2A to 8A through LCD
- Intelligent EBM quantity detection
- Communication ports: EPO, Dry in, Dry out, intelligent slot, USB, RS232
- IoT: Ethernet(default) and Wireless (Optional)
- Dot-matrix LCD, supports Multi-Language
- ECO Mode
- Start-able without battery.

## ENVIRONMENTAL PROTECTION

Products are developed according to an eco-design approach.

### Substances

This product does not contain CFCs, HCFCs or asbestos.

### Packing

To improve waste treatment and facilitate recycling, separate the various packing components.

- The cardboard we use comprises over 50% of recycled cardboard.
- Sacks and bags are made of polyethylene.
- Packing materials are recyclable.

Follow all local regulations for the disposal of packing materials.

### Product

The product is mainly made up of recyclable materials.

Dismantling and disassembly must take place in compliance with all local regulations concerning waste. At the end of its service life, the product must be transported to recycling centres, re-use and treatment facilities for waste electrical and electronic equipment (WEEE).

### Battery

The product contains lead-acid batteries that must be processed according to applicable local regulations concerning batteries.

The battery may be removed to comply with regulations and in view of correct disposal.

## PRODUCT OVERVIEW

### WEIGHT AND DIMENSIONS

! The weights in this table is reference only, please see the labels on the carton for details.

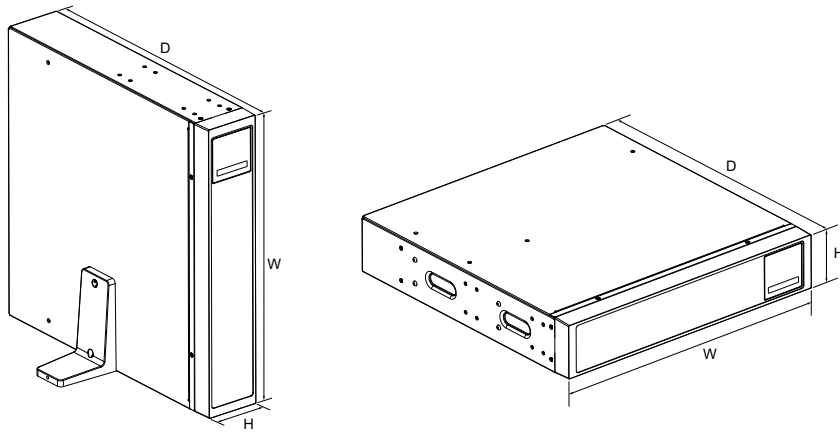

DESCRIPTION	NET WEIGHTS (KG)	DIMENSIONS: D X W X H (mm)
C450R-010-B	14.3	445*438*85.5
C450R-010-C	8.0	445*438*85.5
C450R-020-B	23.3	600*438*85.5
C450R-020-C	10.6	600*438*85.5
C450R-030-B	26.2	600*438*85.5
C450R-030-C	11.0	600*438*85.5
C450R-BB1	22.6	445*438*85.5
C450R-BB2/3P	39.9	600*438*85.5



## REAR PANELS

C450R-010-B/C

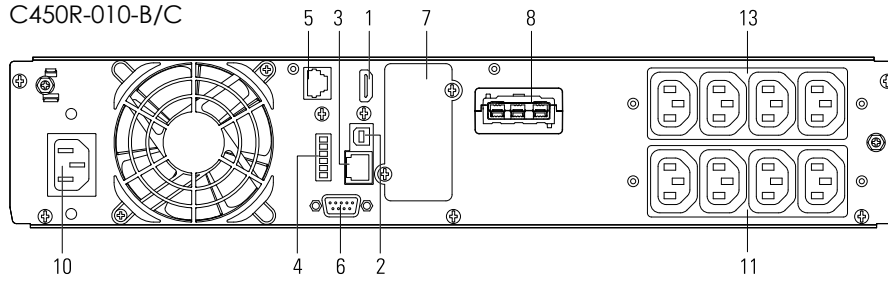

C450R-020-B/C

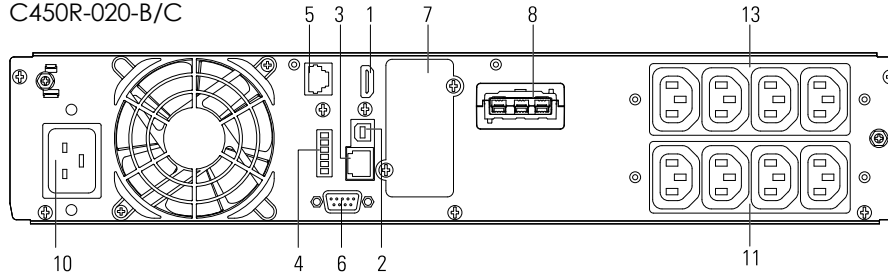

C450R-030-B/C

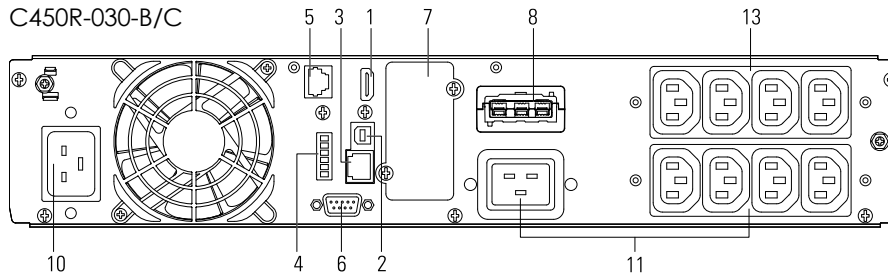

C450R-BB1

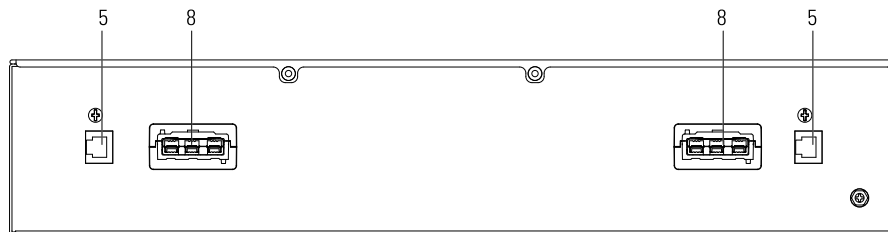

C450R-BB2/3P

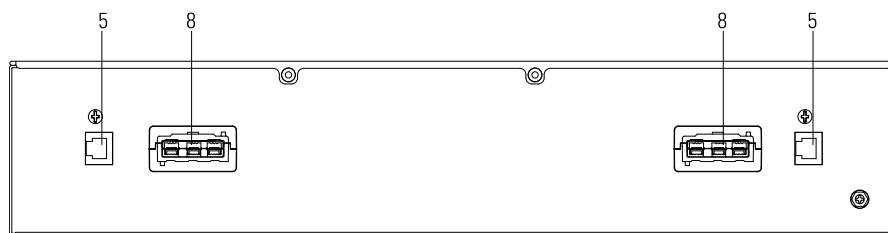

1	WLAN(HDMI)	2	USB	3	Ethernet (RJ45)
4	EPO/Dry in/Dry out	5	EBM auto detection	6	RS232
7	Slot Card Box	8	EBM Connector	10	Input Socket/ Input Terminal
11	Output Socket/ Output Terminal	13	Programmable Output Socket		

## INSTALLATION

### INSPECTING THE EQUIPMENT



If any equipment has been damaged during shipment, keep the shipping cartons and packing materials for the carrier or place of purchase and file a claim for shipping damage. If you discover damage after acceptance, contact your supplier to file a claim for concealed damage.

### CHECKING THE ACCESSORY KIT

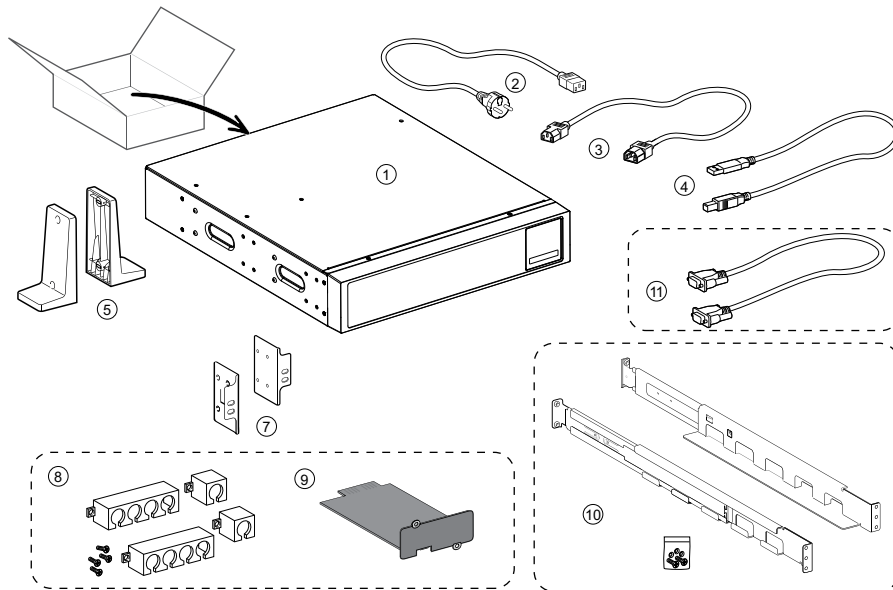

1	UPS	2	Input cable	3	Output cables
4	USB cable	5	Tower stands	7	Rack ears
8	Cable lockers (optional)	9	Intelligent slot card (optional)	10	Rail kit
11	RS232 cable (optional)				

## INSTALLING THE UNIT



Always keep 200mm of free space behind the UPS rear panel



Check that the indications on the name plate located on the top cover of the UPS meets to the AC-power source and the true electrical consumption of the total load.

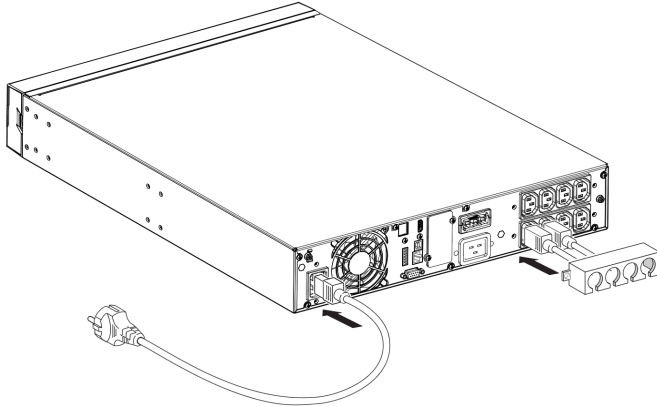

1. Connect the UPS input socket to the AC power source using the cable of the protected equipment.
2. Connect the loads to the UPS using the cables.



**Note:** The UPS charges the battery as soon as it is connected to the AC-power source, even if the power button is not pressed.

Once the UPS is connected to the AC-power source, 8 hours of charging is required before the battery can supply the rated backup time.

## RACK INSTALLATION

Follow steps 1 to 4 for module mounting on the rails

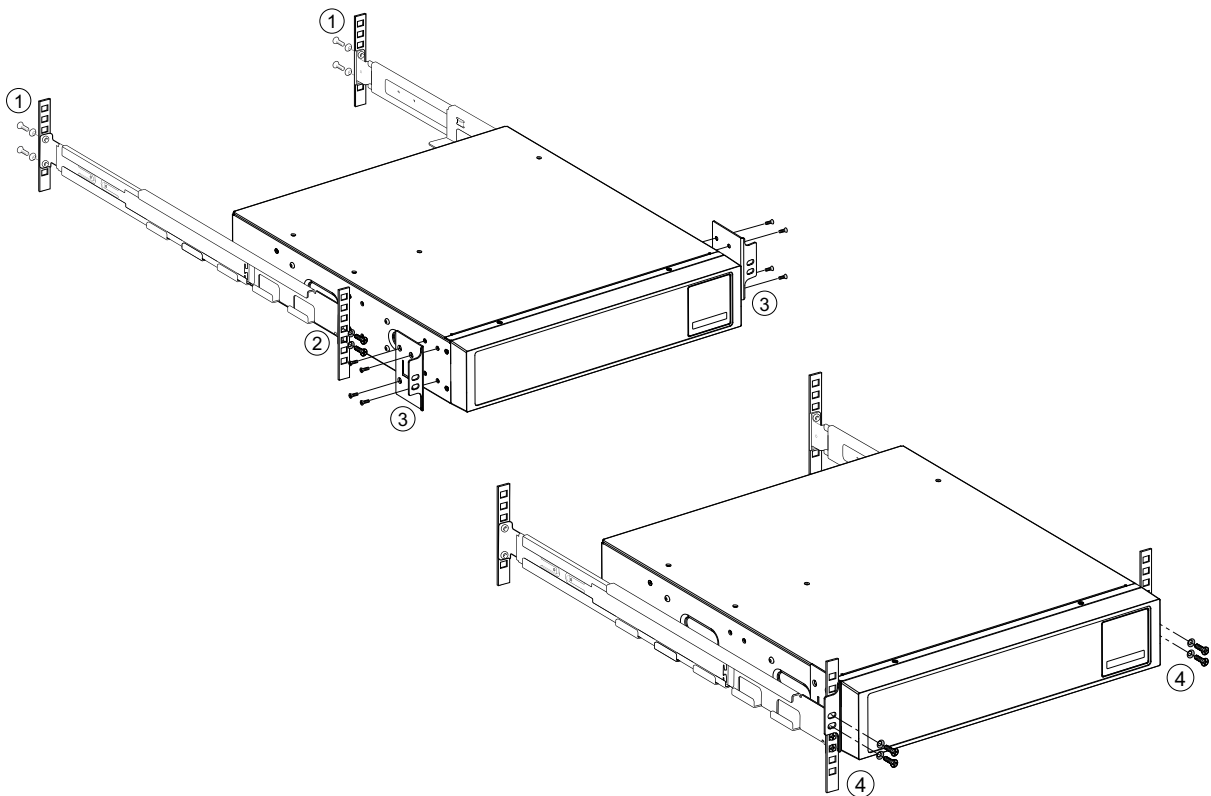

## TOWER INSTALLATION

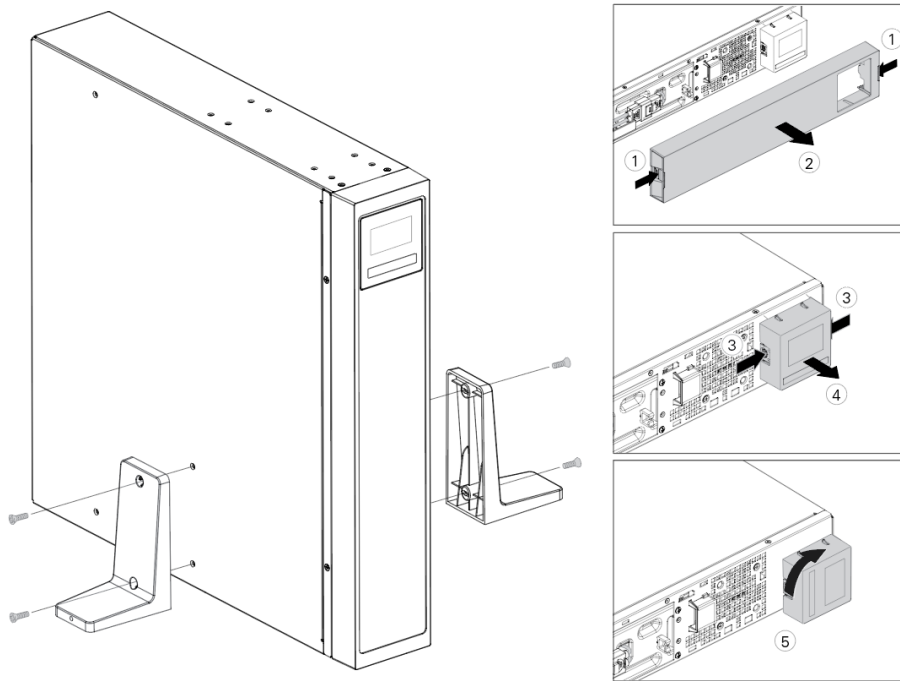

## CONNECTING THE EBM(S)

A small amount of arcing may occur when connecting an EBM to the UPS. This is normal and will not harm personnel.

Up to a maximum of 4 EBMs can be connected to the UPS.

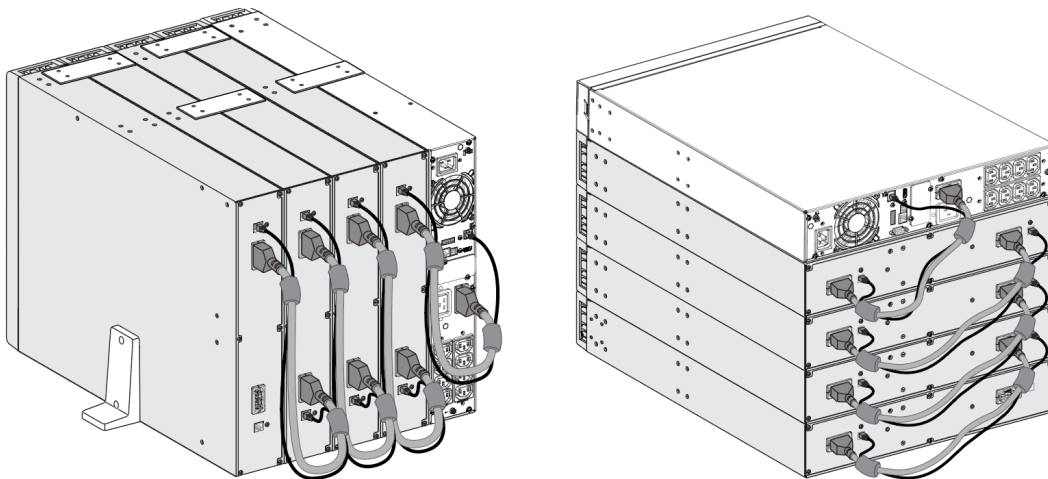

## OPERATION

### LCD PANEL

The LCD panel of the front of the UPS provides useful information about its operation such as load, status, events, measurements and settings.

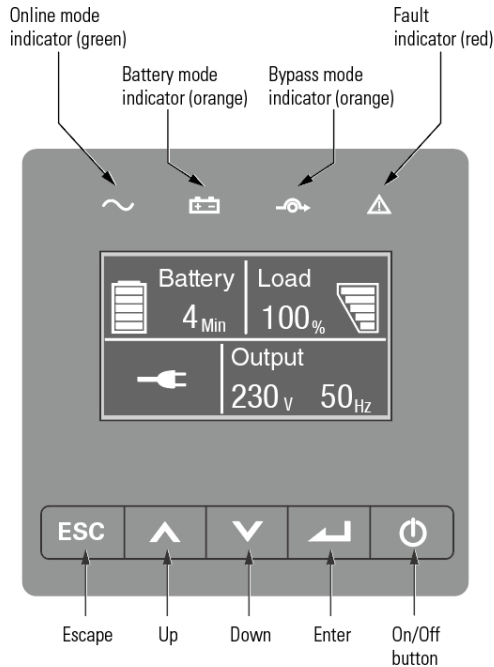

The following table shows the indicator status and description:

Indicator	Status	Description
Green	On	The UPS is operating normally on Online or in High Efficiency mode.
Yellow	On	The UPS is in Battery mode.
Yellow	On	The UPS is on Bypass mode and the load is supplied direct by mains power.
Red	On	The UPS has an active alarm or fault. See <a href="#">Chapter 7 troubleshooting</a> for additional information.

The button	Function	Illustration
	Power on	Pressing this Button for <1s will power on the UPS in standby mode whilst no utility power available but batteries are connected. Holding whilst in standby mode will turn on the UPS in battery mode.
	Turn on	When the Unity is powered on, press the button for >1s can turn on the UPS
	Turn off	Press the button > 3s can turn off the UPS
	Scroll up	Press to Scroll up the menu option
	Scroll down	Press to Scroll down the menu option
	Enter menu	Select/Confirm the current selection
	Exit the present menu	Press to exit present screen the main menu or to return to higher-level menu without changing a setting
	Mute buzzer	Press the button to mute the buzzer temporarily, once new warning or fault is active, buzzer will activate again

## LCD DESCRIPTION

The LCD backlight automatically dims after 10 minutes of inactivity. Pressing any button will restore the screen.

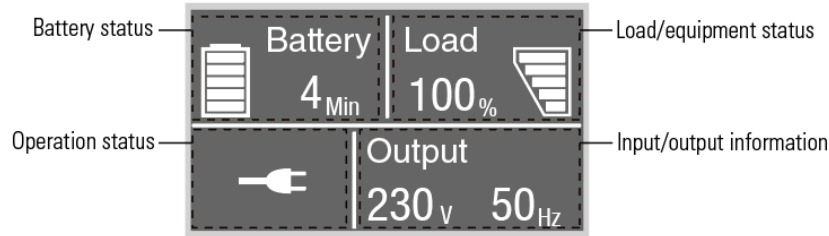

Operation status	Cause	Description
	Standby mode	The UPS is Off without output.
	Online mode	The UPS is operating normally and protecting the equipment.
 1 beep every 4 seconds	Battery mode	A utility failure has occurred, and the UPS is powering the equipment with battery. Prepare your equipment for shutdown.
 1 beep every 1 seconds	Battery mode with battery low	This warning is approximate, and the actual time to shutdown may vary significantly but battery is near fully depleted. .
	High Efficiency mode	Once the mains are loss or abnormal, the UPS will transfer to Line mode or Battery mode and the load is supplied continuously.
	Converter mode	The UPS will free run with fixed output frequency (50Hz or 60Hz). The load should be derated to 60% in converter mode.
	Bypass mode	The UPS is in bypass mode, Overloaded or a fault has occurred forcing the UPS to Bypass mode.
	Battery test	UPS is executing a battery test
	Battery fail	The UPS detects bad battery or battery disconnected
	Overload	The UPS is overloaded, and some unnecessary loads should be removed.
	Fault mode	A critical error has occurred, please contact your service provided.

## DISPLAY FUNCTIONS

When starting the UPS, the display is in the default UPS status summary screen.

Main menu	Submenu	Display information or Menu function
UPS status		UPS mode, IoT status, date/time, battery status and current alarms
Event log		Displays the events and faults stored
Measurements		[Load] W, VA, A, P%, [Input/Output] V, Hz, [Battery] %, min, V, EBM [DC Bus] V, [Temperature] C
Control	Go to Bypass	Transfers the UPS to Bypass mode
	Load segment	Output Load segment on/off
	Start battery test	Starts a manual battery test
	Reset fault state	Clear active fault
	Reset event list	Clear events and faults
	Reset com card /Reset IoT	Reset IoT and Modbus TCP function inside UPS
	Restore factory settings	Restore to default factory settings
Settings		Refer to <a href="#">chapter 4.4</a> User settings
Identification		[Product name], [Serial number], [firmware version], [IP/MAC address]

## USER SETTINGS

Submenu	Available settings	Default settings
Password	Can be changed by user	4314
Change language	English, Italiano, Français, Deutsch, Español, Русский	English
User password	[Enabled, ****], [Disabled]	Enabled
Audible alarms	[Enabled], [Disabled]	Enabled
Output voltage	[200V], [208V], [220V], [230V], [240V]	[230V]
Output frequency	[autosensing], [Converter 50Hz]	Autosensing
High efficiency mode	[Disabled], [Enabled]	Disabled
Auto bypass	[Disabled], [Enabled]	Disabled
Start/Auto restart/Start from bypass	[Disabled], [Enabled]	Cold start/Auto restart: enabled Start from bypass: disabled
Site wiring fault	[Enabled], [Disabled]	disabled
Overload pre-alarm	[50%~105%]	105%
External battery	[Auto detection], [Manual EBM: 0~4],	Auto detection 0 EBM
Charger current	[2A], [4A], [6A], [8A] for long	4A

Submenu	Available settings	Default settings
Dry in signal	[Disabled], [Remote on], [Remote off], [Forced bypass]	disabled
Dry out signal	[load powered], [on bat], [Low bat], [bat open], [bypass], [ups ok]	bypass
Ambient temperature alarm	[enabled], [disabled]	enabled
Battery remaining time	[enabled], [disabled]	enabled
Date and time	dd/mm/yyyy hh:mm	01/01/2020 00:00
LCD contrast	[-5 ~ +5]	[0]
IoT	[enabled], [disabled]	disabled
Modbus TCP	[enabled], [disabled]	disabled
Overload pre-alarm	[50%~105%]	105%
External battery	[Auto detection], [Manual EBM: 0~4], [Manual Ah: 7~144Ah]	Auto detection 0 EBM
Charger current	For Charger model only - [2A], [4A], [6A], [8A]	4A



If the load type is transformer type, it is recommended to enable the "start from bypass" function



## STARTING THE UPS WITH UTILITY

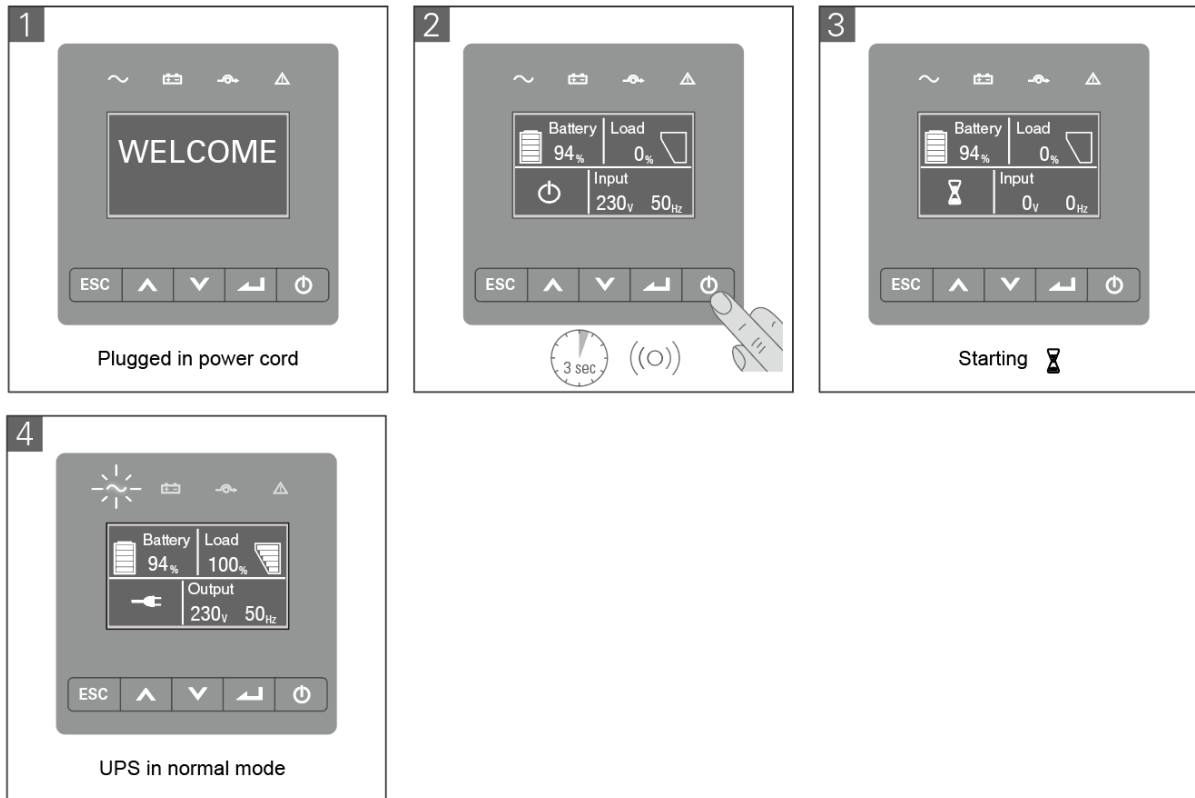

## STARTING THE UPS WITH BATTERY

Before using this feature, the UPS must have been powered by utility power with output enabled at least once.

Battery start can be disabled. Refer to the Chapter [4.4 User setting](#)

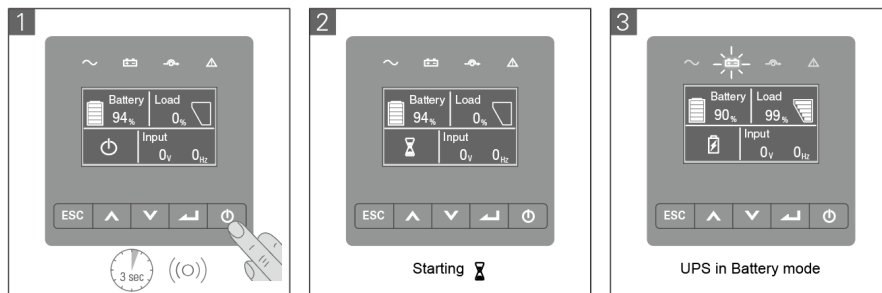

## UPS SHUTDOWN

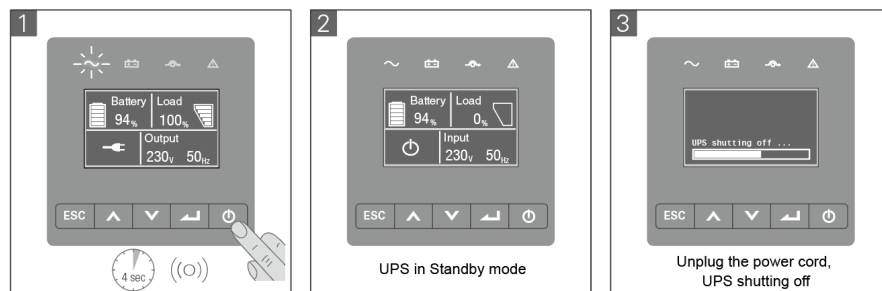

## COMMUNICATION

RS232 and USB

1. Connect communication cable to the serial or USB port on the computer
2. Connect the other end of the communication cable to the RS232 or USB communication port on the UPS

## UPS REMOTE CONTROL FUNCTIONS

Remote power off (RPO) also known as Emergency power off (EPO)

When RPO is activated, UPS will cut off output immediately, and continue to alarm.

RPO	Comments
Connector type	1.3mm (16 AWG) Maximum wires
External breaker specification	60 V DC/30 V AC 20 mA max

## Dry in

Dry in function can be configured (see settings > Dry in)

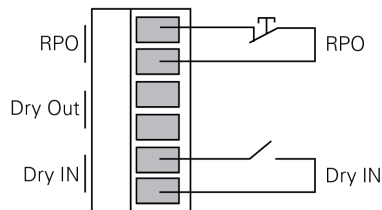

Dry in	Comments
Connector type	1.3 (16 AWG) Maximum wires
External breaker specification	60 V DC/30 V AC 20 mA max

## Dry Out

Dry out is the relay out, dry out function that can be configured (see Settings > Dry out).

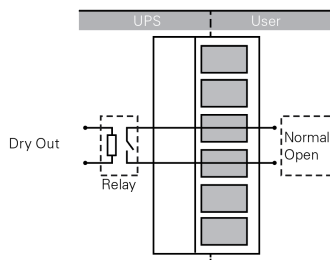

Dry out	Comments
Connector type	1.3mm (16 AWG) Maximum wires
Inner Relay specification	24Vdc/1A

## IoT (INTERNET OF THINGS)

The built-in ethernet port and WLAN port (optional accessory) enable market-leading and easy-to-use IoT solutions for:

- CertaUPS App - Mobile app which allows you to remote monitor UPS(s) and keeps informed about critical UPS events always.
- Remote report UPS faults and status (contact with your service for detail) from APP or registered APP account (Email address).
- Automatic UPS and battery warranty alert from APP or registered APP account (Email address).

### IoT Connection

#### Wired connection

1. Connect UPS and router or switch with a network cable

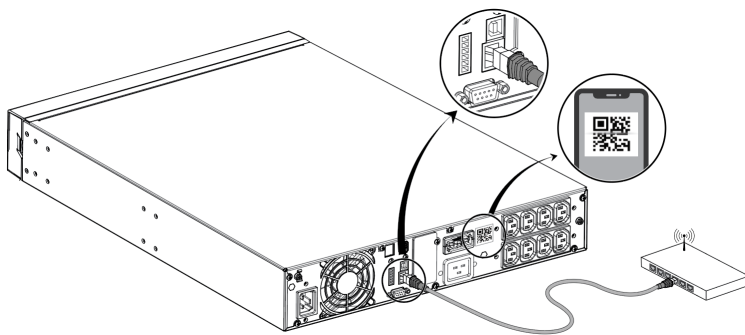

Please use CAT6 shielded network cable.

The Position of the QR code on the UPS is for reference, subject to the actual UPS label.

Make sure your IT settings can access the public network and Microsoft Azure Cloud.

2. Enable the IoT function in LCD (see Settings -> IoT)
3. Search for "WinPower View" from Google Play Store or Apple APP store, download and install.
4. Open the app, register an account, log in, follow the instructions of the app.
5. Tap on the upper right corner, scan the SN barcode on the UPS label to add a device.

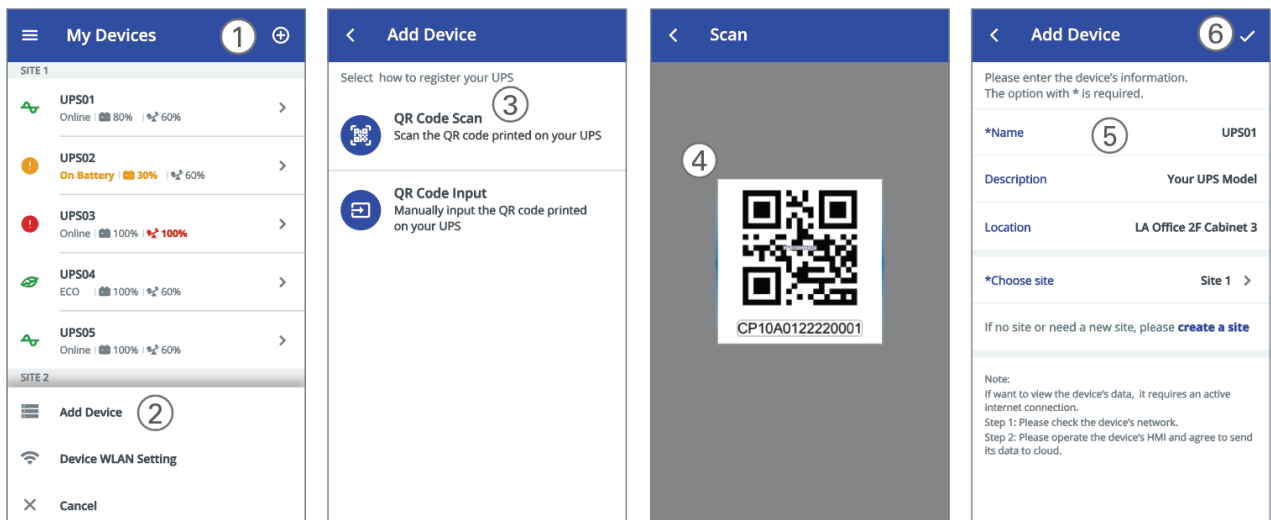

For more detailed information and Q&A about the IoT and APP, please refer to the HELP menu in the APP

## Wireless connection

The wireless module (C-WIFI) is optional, please contact your local CertaUPS representative for details

## MODULAR TCP

The built-in ethernet port offers a Modbus TCP feature to facilitate remote monitoring of the UPS into your software. Please contact your local CertaUPS representative for product details.

## INTELLIGENT CARD (OPTIONAL)

Intelligent Card allows UPS to communicate with different types of devices in a variety of networking environments. The UPS could use the following connectivity cards, please contact your local distributor for details.

- **C-NMC** - Ideal monitoring solution enables the user to monitor and control the status of UPS on a web browser via internet.
- **C-Modbus** - provides a connection to Modbus protocol with standard RS485 signal.
- **C-Relay** - Provides voltage-free dry-contact signals for programmable controller and management system.
- **C-EMP** - Supports temperature and humidity sensors for remote environment monitoring, should work with C-NMC Card.

## UPS MANAGEMENT SOFTWARE

WinPower provides a user-friendly interface to monitor and control your UPS. This unique software provides safe auto-shutdown for multi-computer systems during a power failure. With this software, users can monitor and control any UPS on the same LAN no matter how far from the UPSs.

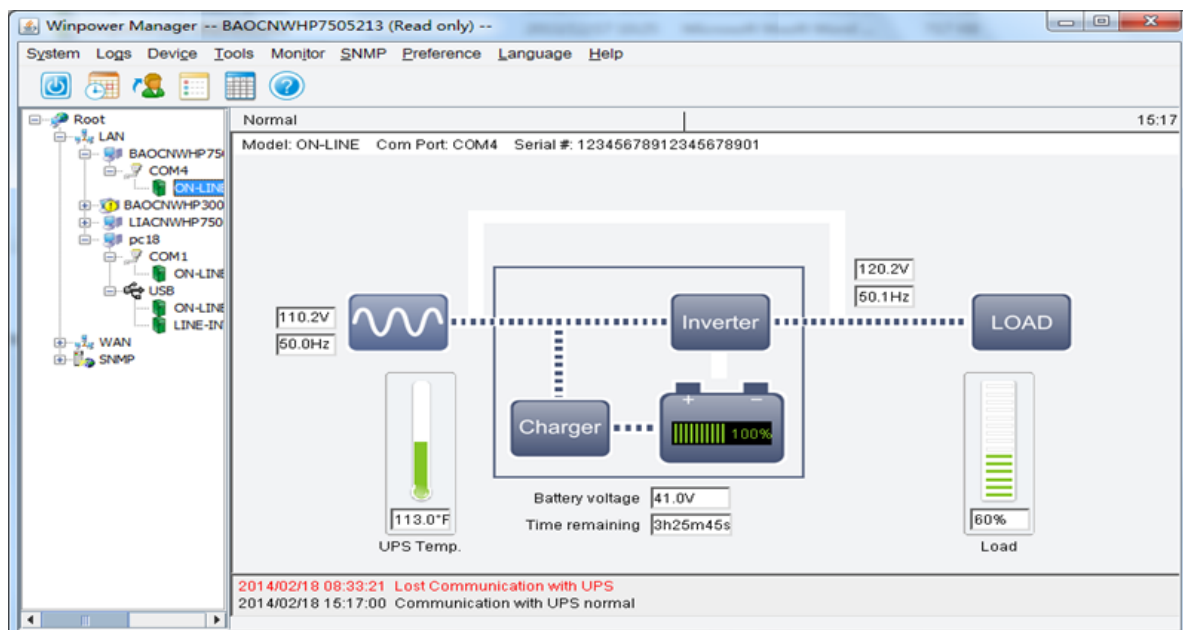

## INSTALLATION PROCEDURE:

1. Go to the website:

<http://www.ups-software-download.com/content/ups-download-software/download.html>

2. Choose the operating system you need and follow the instruction described on the website to download the software.
3. When downloading all required files from the internet, Please enter the serial number below to install the software.

**Serial number: 511C1-01220-0100-478DF2A**

When you finish installation, restart your computer, the WinPower software will appear as a green plug icon located in the system tray, near the clock.

## CertaUPS APP

The CertaUPS mobile App allows you to centralise monitoring UPS(s) connected to the cloud. Please download it from the Google Play Store or Apple APP store.

Please refer to [chapter 5.3](#) for IoT connection.

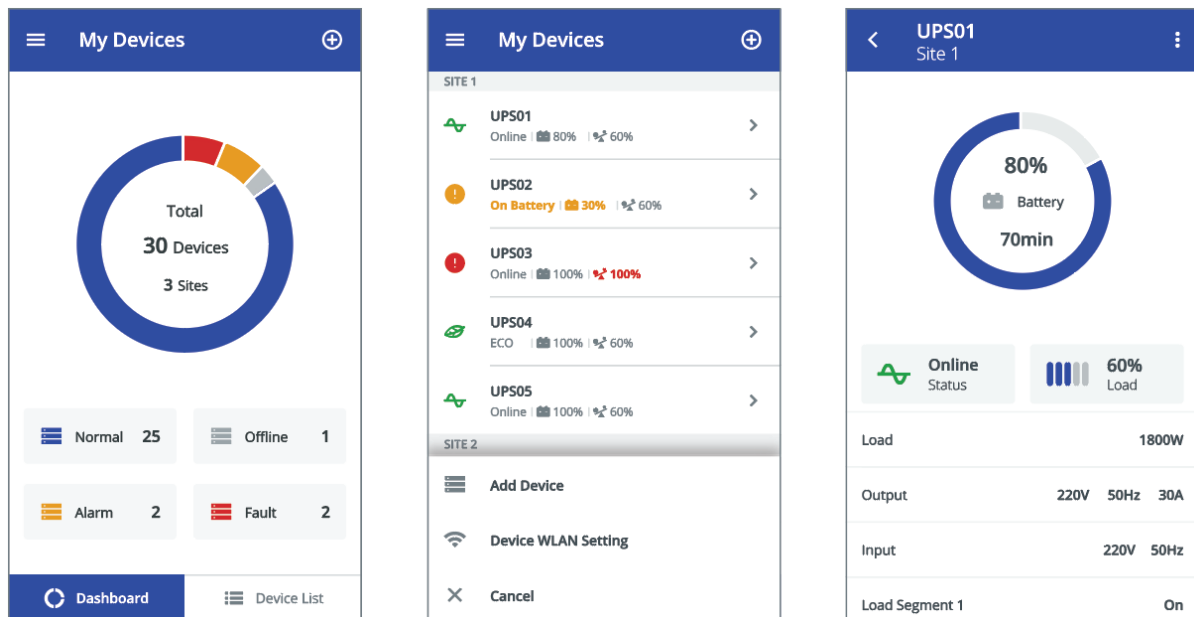

## UPS MAINTENANCE

### EQUIPMENT CARE

For the best preventive maintenance, keep the area around the equipment clean and dust-free. If the atmosphere is very dusty, clean the outside of the system with a vacuum cleaner.

For full battery life, keep the equipment at a maximum ambient temperature of 25°C (77°F).



The batteries are rated for a 3 to 5-year service life. The length of service life varies, depending on the frequency of usage and ambient temperature. Batteries used beyond expected service life will often have severely reduced runtimes. Replace batteries at least every 4 years to keep units running at peak efficiency.

### TRANSPORTING THE UPS



Please transport the UPS only in the original packaging. If the UPS requires any type of transportation, verify that the UPS is disconnected and turned off.

### STORING THE EQUIPMENT

If you store the equipment for a long period, recharge the battery every 6 months by connecting the UPS to utility power. Recommends that the batteries charge for 48 hours after long-term storage.

If batteries were never recharged over 6 months, do not use them. Contact your service representative.

### REPLACING BATTERIES



DO NOT DISCONNECT the batteries while the UPS is in Battery mode.



Consider all warnings, cautions, and notes before replacing batteries.

- Servicing should be performed by qualified service personnel knowledgeable of batteries and required precautions. Keep unauthorized personnel away from batteries.

## Replacing the internal battery (For R models)

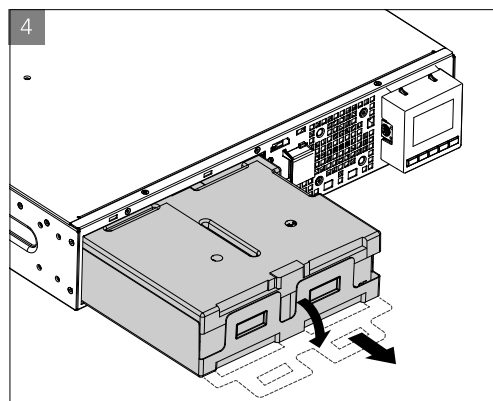
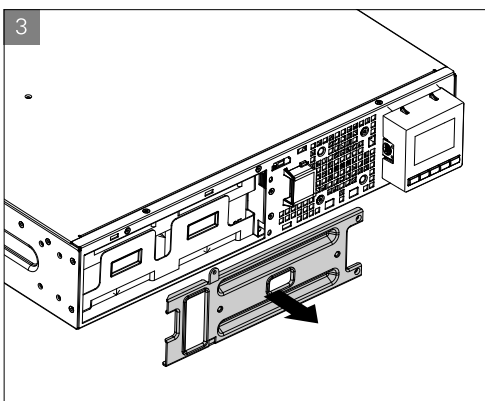
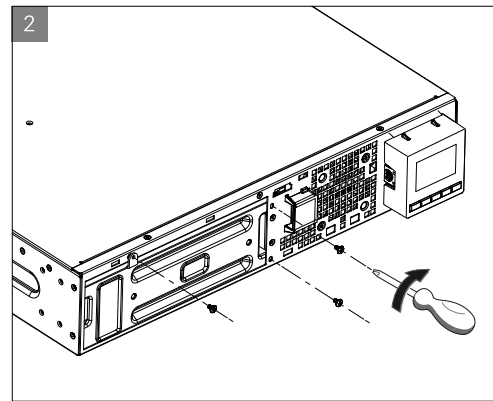
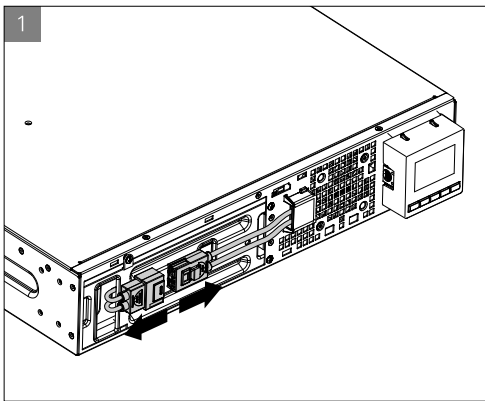
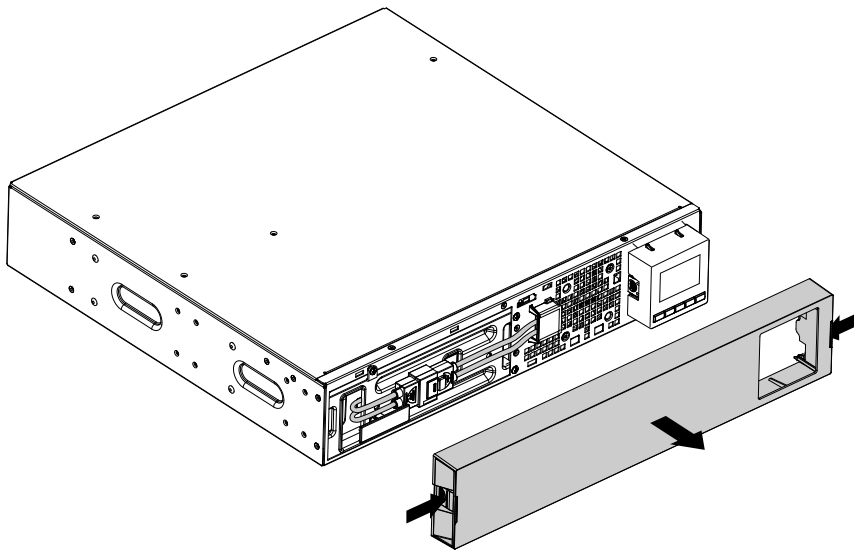

### Installing the new Battery pack

1. Put the new battery pack into the UPS.
2. Screw back the metal protection covers.
3. Reconnect the electrical connector and the front panel.
4. Perform a manual battery test from the display.



Verify that the replacement batteries have the same rating and brand as the batteries being replaced.

## RECYCLING

Contact your local recycling or hazardous waste centre for information on the proper disposal of the used equipment.



Do not dispose of the batteries in the fire. Which may cause a battery explosion. The batteries must be rightly disposed of according to local regulations.

Do not open or destroy the batteries. Escaping electrolytes can cause injury to the skin and eyes. It may be toxic.



**Pb**

Do not discard the batteries in the trash.

This product contains sealed lead-acid batteries and must be disposed of as it's explained in this manual. For more information, contact your local recycling centres, re-use and treatment facilities.









The crossed-out wheeled bin symbol indicates that waste electrical and electronic equipment (WEEE) should not be discarded together with unseparated household waste but must be collected separately. The product should be handed in for recycling in accordance with the local environmental regulations for waste disposal.

By separating waste electrical and electronic equipment, you will help reduce the volume of waste sent for incineration or landfills and minimize any potential negative impact on human health and the environment.



## TROUBLESHOOTING

Conditions	Possible cause	Action
Battery mode  LED is On. 1 beep every 4 seconds.	A utility failure has occurred, and the UPS is in Battery mode.	The UPS is powering the equipment with battery power. Prepare your equipment for shutdown.
Battery low  LED is On. 1 beep every second.	The UPS is in Battery mode and the battery is running low.	This warning is approximate, and the actual time to shutdown may vary significantly.
No battery  LED is On. Beep continuous.	The batteries are disconnected.	1. Verify that all batteries and battery detection cable (RJ45) are properly connected. 2. Check the LCD menu: Settings – External battery. If select the “Manual EBM” and Value is 0, please set the right value.
Battery fault  LED is On. Beep continuous.	The battery test has failed due to bad or disconnected batteries, or the battery minimum voltage is reached in Optimize Battery Management (OBM) cycling mode.	Verify that all batteries are properly connected. Start a new battery test: if the condition persists, contact your service representative.
The UPS does not provide the expected backup time.	The batteries need charging or service.	Apply utility power for 48 hours to charge the batteries. If the condition persists, contact your service representative.
Bypass mode  LED is on.	An overload or a fault has occurred, or a command has been received and the UPS is in Bypass mode. Or auto bypass function is enabled.	Equipment is powered but not protected by the UPS. Check for one of the following alarms: overtemperature, overload, UPS failure or auto bypass setting.
Power overload  LED is On. 1 beep every second.	Power requirements exceed the UPS capacity (greater than 105% of nominal);	Remove some of the equipment from the UPS. The alarm resets when the condition becomes inactive.
Over temperature warning  LED is On. 1 beep every second.	The UPS internal temperature is too high. At the warning level, the UPS generates the alarm but will remains in the current operating state.	Clear vents and remove any heat sources. Ensure the airflow around the UPS is not restricted.
The UPS does not start.	The input source is not connected correctly.	Check the input connections.
	The Remote Power Off (RPO) switch is active or the RPO connector is missing.	If the UPS Status menu displays the "Remote Power Off" notice, inactivate the RPO input.
Emergency power off	RPO is active	1.Check the RPO connector status 2.Reset the RPO fault through LCD. Main menu – Control - Reset fault state.

Conditions	Possible cause	Action
Fan fault	Fan abnormal	Check if the fan is running normally
Site fault	Phase and neutral conductor at input of UPS system are reversed	Site Fault detection disabled by default. It can still be enabled / disabled from the LCD settings menu. Reconnect all input wires.
Over temperature fault	Over temperature is too high, UPS goes to bypass or stopped.	Check the ventilation of the UPS and check the ambient temperature.
Output short circuit	Output short circuit occurred.	Check the output of UPS and loads, make sure the short circuit is removed before turning on again.
APP cannot connect to UPS	IoT is disabled	Enable IoT function in LCD
	Your IT settings may block UPS get cloud connected (NTP, Proxy, etc.)	please refer to CertaUPS app help file

## SPECIFICATIONS

### UPS BLOCK DIAGRAM

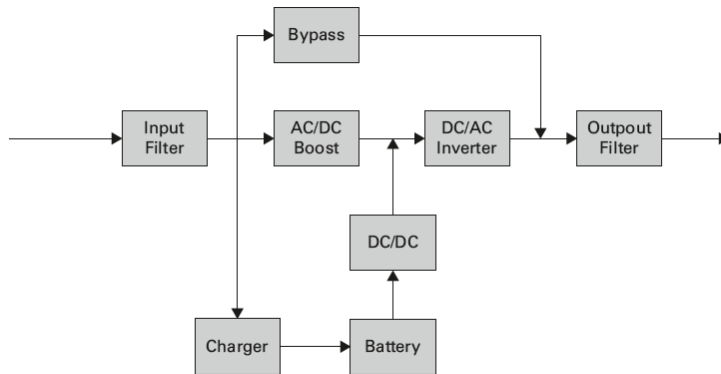

### UPS SPECIFICATION

Model	C450R-010-B	C450R-010-C	C450R-020-B	C450R-020-C	C450R-030-B	C450R-030-C
Capacity	1000VA / 1000W		2000VA / 2000W		3000VA / 3000W	
<b>EFFICIENCY</b>						
Line Mode	89%		93%			
ECO Mode	96%		97%			
<b>INPUT</b>						
Input Voltage Range	Optimize Battery Management (OBM)					
Frequency	50Hz / 60Hz					
Power Factor	>0.99					
THDI	<5%					
<b>INPUT CONNECTION</b>						
Socket	1x IEC C14		1x IEC C20			
<b>OUTPUT</b>						
Voltage Regulation (AC Mode)	200/208/220/230/240 VAC (derating 10% at 208V, derating 20% at 200V)					
Rated Frequency	50Hz / 60Hz					
Maximum Power Factor	PF = 1					
Voltage accuracy	±1%					
THDv	<1% linear load; <5% nonlinear load					
Transfer Time	0ms Online -> battery; 4ms Online -> bypass; 10ms ECO -> Inverter					
Waveform (batt. Mode)	Pure sine wave					
Crest Ratio	Max 3:1					

Overload Capacity	100%<load≤105% continuous. 105%< load ≤125% for 3 minutes. 125%<load≤150% for 30 seconds >150% for 500ms					
<b>OUTPUT CONNECTION</b>						
Socket	1 main outlet group (with 4 x IEC C13) 1 programmable outlet group (with 4 x IEC C13)			1 main outlet group (with 1 x IEC C19 + 4 x IEC C13) 1 programmable outlet group (with 4 x IEC C13)		
Load Segment Control	1 programmable load segment control					
<b>SHORT CIRCUIT CURRENT</b>						
Bypass Mode	550A / 2.8ms		699A / 7ms			
Normal / Battery Mode	20A / 100ms		36A / 100ms		54A / 100ms	
<b>BATTERY</b>						
Voltage	36V		72V			
Maximum EBM quantity	4					
EBM Auto Detection	Yes					
Battery Hot Swappable	Yes					
<b>CHARGER</b>						
Charging Method	Optimize Battery Management (OBM)					
Charging Current	1.5A	8A	1.5A	8A	1.5A	8A
Recharge Time	3h to 90%	N/A	3h to 90%	N/A	3h to 90%	N/A
<b>OTHER MODE</b>						
CVCF	Yes (deterating to 60% load)					
<b>HMI</b>						
Display	Dot matrix LCD (optional segment LCD)					
Language	Multi-language					
USB	USB 2.0 with HID power device					
RS232	Yes (DB9)					
Dry in/out	1 programmable dry in; 1 programmable dry out					
RPO	Yes					
Intelligent Slot	Yes					
Network Card	Optional, NMC					
Modbus Card	Optional, CMC					
Dry Contactor Card	Optional, AS400					
Wireless Module	Optional					
IOT Ethernet Port	RJ45					
Monitoring Software	Winpower, CertaUPS Monitor App					

<b>PHYSICAL PERFORMANCE</b>		
Dimension (WxDxH) mm	438 x 445 x 85.5 (2U)	438 x 600 x 85.5 (2U)
IP Protection Level	IP20	
<b>ENVIRONMENT</b>		
Operating Temperature	0-40°C	
Relative Humidity	0-95%	
Operating Altitude	0-3000m (the load derating 1 % every up 100m @1000~3000m)	
Acoustic Noise	<45dB at front 1m	<50dB at front 1m
Certification	CE, IEC/EN 62040, UKCA	
<b>EMS</b>		
ESD	EC/EN 61000-4-2	
RS232	IEC/EN 61000-4-3	
EFT	IEC/EN 61000-4-4	
Surge	IEC/EN 61000-4-5	
<b>ACCESSORIES</b>		
Input Power Cable	Yes	
Output Power Cable	Yes (For IEC models)	
EBM Cable	Yes (in EBM)	
USB Cable	Yes	
Rail Kit	Included	
Tower Feet	Yes	
Rack Ears	Yes	
Manual (English)	Yes	